

HOT SHOT

IRRIGATION

810-3R

RECEIVER GUIDE

Pg.

2	HOT SHOT OVERVIEW
3	RECEIVER FUNCTION SWITCH SETTINGS
4	RECEIVER INDICATOR LIGHTS
4	SUPERVISION FEATURE
5	RECEIVER HOOKUP TO ENGINE DRIVEN WELL
6	RECEIVER HOOKUP TO ELECTRIC WELL
7	RECEIVER HOOKUP TO ELECTRIC WELL DIAGRAM

HOT SHOT OVERVIEW

ATTENTION: Depending upon the style of system that your are going to control with the Hot Shot Wireless Controller you may need to supply additional parts. Such as relays, step-down transformers, Murphy switches etc. These items are suggested in the wiring guides that follow in this manual.

HOW IT WORKS

Think of the HOT SHOT system as a 12-2 control wire going from the pivot to the irrigation pump. When the Hot Shot Transmitter's RELAY Input is activated, a 15 second delay timer is started. After the delay timer has expired, the transmitter will send the (turn ON) command to the receiver. This transmission will close the relay contacts at the pump to start water. When the pivot is done irrigating or when the safety is tripped, the pivot will open the Hot Shot Transmitter's RELAY Input contacts and send the (turn OFF) relay command to stop water. Battery backup in the transmitter will still allow the HOT SHOT to work in case of a pivot power outage. Each system is coded with its own four digit code so it will not interfere with other systems in the same area. The following manual has been prepared to provide details for Transmitter installation and Receiver installation on electric and engine driven wells.

MOUNTING

Cabinets are a weatherproof UV protected NEMA 4X cabinet with mounting ears on top and bottom. The Hot Shot cabinet can be mounted on the side of a control panel, pole or any other surface as long as the antenna does not have metal running within 12" of the antenna whip. If longer range is needed, an external long range antenna can be used. Do not mount the HOT SHOT receiver to the well engine or cover because the strong vibrations can be harmful to the unit.

CODE SWITCH SETTINGS

All transmitters and receivers will be shipped from the factory with preprogrammed field codes. This ensures that your neighbor will not duplicate the same field code as your unit. Your field codes already match, so you do not need to program any codes. If you ever need to replace a unit due to servicing, the field code can be programmed to match the existing or new add on units. FOLLOW THE EXAMPLE BELOW...

FOR CODE QUESTIONS? CALL 785-623-1500

EXAMPLE: CODE 6789

KEY

3	4	5	6
7	8	9	0

Use the # KEY to the left to make each digit of the code. It takes three of the switches to make one number of the code.

Use switches 1,2,3 for the first # in the code. Switches 4,5,6 for the second #. Switches 7,8,9 for the third #. Switches 10,11,12 for the fourth #.

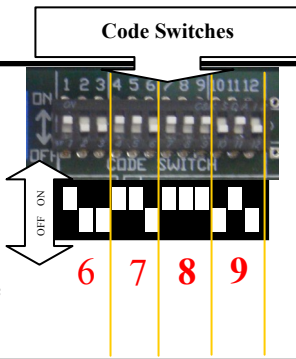

RECEIVER UNIT 810-3R

FUNCTION SWITCH SETTINGS

SWITCH#	WHAT RELAY WILL DO WHEN ACTIVATED	
1	ON	RELAY WILL LATCH MOMENTARILY FOR 10 SEC AND THEN REOPEN.
	OFF	RELAY WILL STAY LATCHED UNTIL RESET CODE IS SENT.
2	ON	INVERT FUNCTION – AT POWER UP RELAY BECOMES ENERGIZED. <i>(COMMON TERMINAL IS CLOSED TO N.O. TERMINAL)</i>
	OFF	RELAY STARTS IN THE DEFAULT POSITION WITH N.C. CLOSED TO COM.
3	ON	ACTIVATION OF RELAY DELAYED BY 10 SEC. <i>(SEE LOAD SHARING FEATURE)</i>
	OFF	NO 10 SEC DELAY OF RELAY.
4	ON	ACTIVATION OF RELAY DELAYED BY 5 MIN. <i>(NO DELAY ON SHUTDOWN.)</i>
	OFF	NO 5 MIN DELAY.
5-7	NOT USED	
8	ON	ACTIVATES THE SUPERVISION STROBE LIGHT
	OFF	DEACTIVATES THE SUPERVISION STROBE LIGHT
9	NOT USED	

Load Sharing Feature - DIFFERENT DELAY TIMES OF PUMPS STARTING CAN HELP WITH LARGE ELECTRICAL CURRENT PULLS IN THE SAME FIELD.

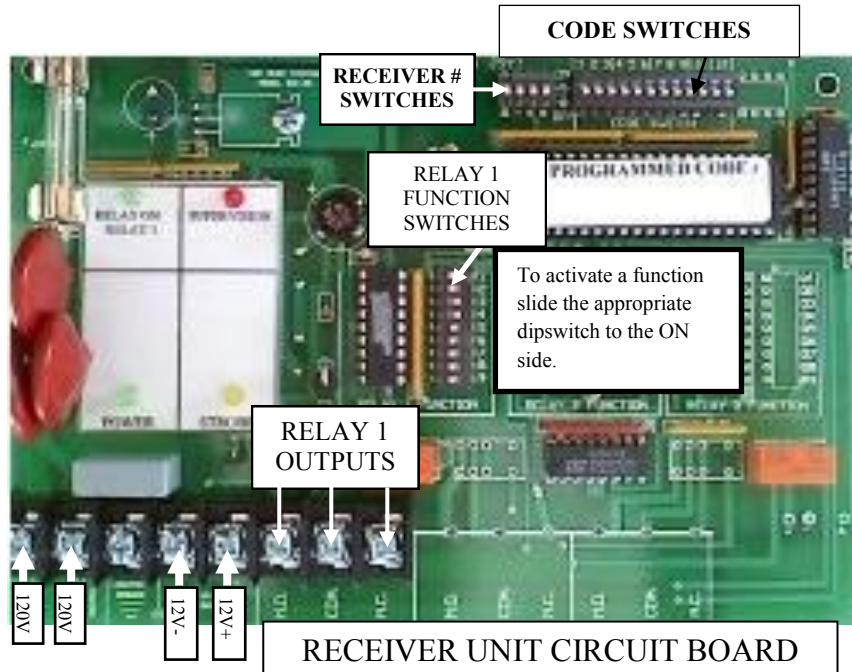

RECEIVER UNIT 810-3R

INDICATOR LIGHTS

- | | | |
|---|--------------------|---|
| 1 | POWER | Signals that the Receiver has power and is ready to receive the code from the Transmitter. |
| 2 | STROBE | Used for troubleshooting, this light flashes once for each of the four correct digits of the code received. The light will stay on steady for one second if an incorrect digit of the code is received. <i>Example: If the light flashes two times and then goes on steady it is indicating that the third digit doesn't match. If the light flashes one time and goes on steady it is indicating that the second digit doesn't match. If the light comes on steady right away it is indicating that the first digit doesn't match.</i> |
| 3 | RELAY | When this light is on it indicates that its corresponding relay has been activated. |
| 4 | SUPERVISION | When this light is flashing it indicates that it has not received its correct code from the transmitter in the past 3hrs. Sliding function switch #8 to its OFF position will turn off this indicator light. |

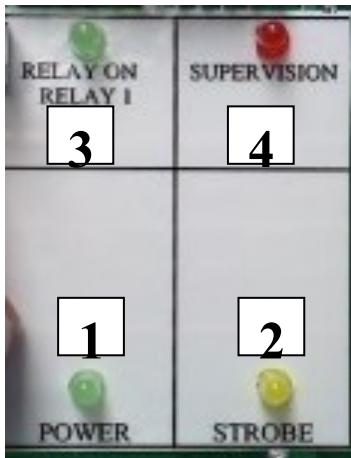

SUPERVISION FEATURE

The Supervision Feature is a great way for checking at a glance the integrity of the system. The RED Supervision Light will come on if the receiver has not heard its correct code from the transmitter within the past three hours. Then the Supervision Light will begin to blink until the receiver hears its correct code again. If there are two or more receivers on the same transmitter and the Supervision Light is blinking on both of them, it is indicating that the transmitter is either turned off or malfunctioning. If only one out of the two receiver's Supervision Lights are blinking, it is indicating that that receiver is malfunctioning and that the other receiver and transmitter are working properly.

RECEIVER # SWITCHES(1,2,3)

USE WITH A PLUS MODEL (810-3TPLUS) TRANSMITTERS #2 OR #3 INPUTS.

When a Hot Shot Receiver (only 810-3R) is going to be used with A Hot Shot 810-3TPLUS transmitter using its #1, #2 and #3 RELAY INPUTS, the receivers going to be used will need to be assigned to the sensor on the transmitter that will control it. All receivers come factory set in the default mode as a #1 receiver. Meaning they are only controlled by the RELAY INPUT #1 of the transmitter. When using the RELAY INPUT #2 and or RELAY INPUT #3 of the transmitter you will need to use the **FOUR DIP SWITCHES** located to the left of the

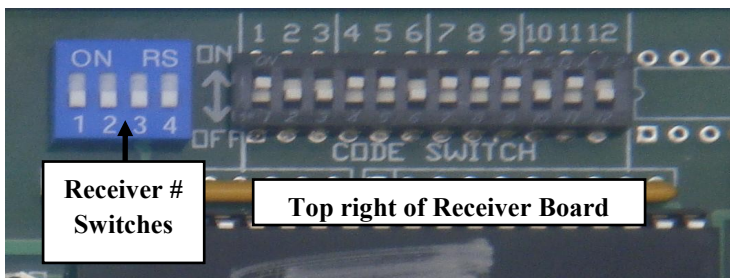

12-digit code bar on the receiver (*see*) to program the receiver so it can be controlled by its designated Relay Input on the transmitter. You can make it a #2 receiver (*which is controlled by the #2 sensor on the transmitter*) by only turning on the #2 dip-switch. You can make it a #3 receiver (*which is controlled by the #3 sensor on the*

transmitter) by only turning on the #3 dipswitch. This makes it capable for the pivot to control and share multiple wells. Also see Discrete Operation and Multi Pivot Operation in the transmitter section.

RECEIVER UNIT 810-3R

TYPICAL HOT SHOT RECEIVER HOOKUP TO KILL AN ENGINE DRIVEN WELL

HOT SHOT RECEIVERS NEED TO BE TURNED ON BEFORE THE HOT SHOT TRANSMITTERS ARE TURNED ON. HOT SHOT TRANSMITTER ONLY TRANSMIT FOR 1 MINUTE. IF THE RECEIVER IS TURNED ON AFTER THE TRANSMITTER IT WILL NOT OPERATE CORRECTLY UNTIL THE TRANSMITTER IS SET TO TRANSMIT AGAIN.

AT THE ENGINE

DO NOT mount the HOT SHOT Receiver unit to the well engine or engine cover because strong vibrations can be harmful to the unit.

The diagrams below show a simple way to control an engine driven well using a simple 117 or 518 Murphy kill switch. Supply power to the receiver by hooking up the 12v positive input on the receiver to the 12v positive terminal on the battery. Run a wire from the Negative input on the receiver to the negative terminal on the battery or to a good ground connection. Install a jumper wire connecting the negative terminal to the COM terminal on the receiver. Connect a wire from the N.C. terminal on the Hot Shot receiver to the S or the SW1 terminal on the Murphy kill switch. Then install a simple on-off (bypass) switch between the NC and the S or the SW1 terminal. This bypass switch is needed because there will not yet be any water pressure at the pivot and the receiver's COM and NC contacts will not open until the water is pressured up and the pivot is requesting water. Now, with the switch opened, it will act as a bypass to let the engine start and get the water pressured up. Once the water is pressured up and the pivot is set to request water the receiver's green RELAY ON light will illuminate and open the contacts. Now, the bypass switch can be closed so that when the pivot is finished and the receiver is sent a stop water signal, the receiver's relay will close COM to NC. This shorts the S terminal to ground and kills the engine. Other variations and Murphy Kill switches will work as well.

Engine Driven Well Hookup Diagrams

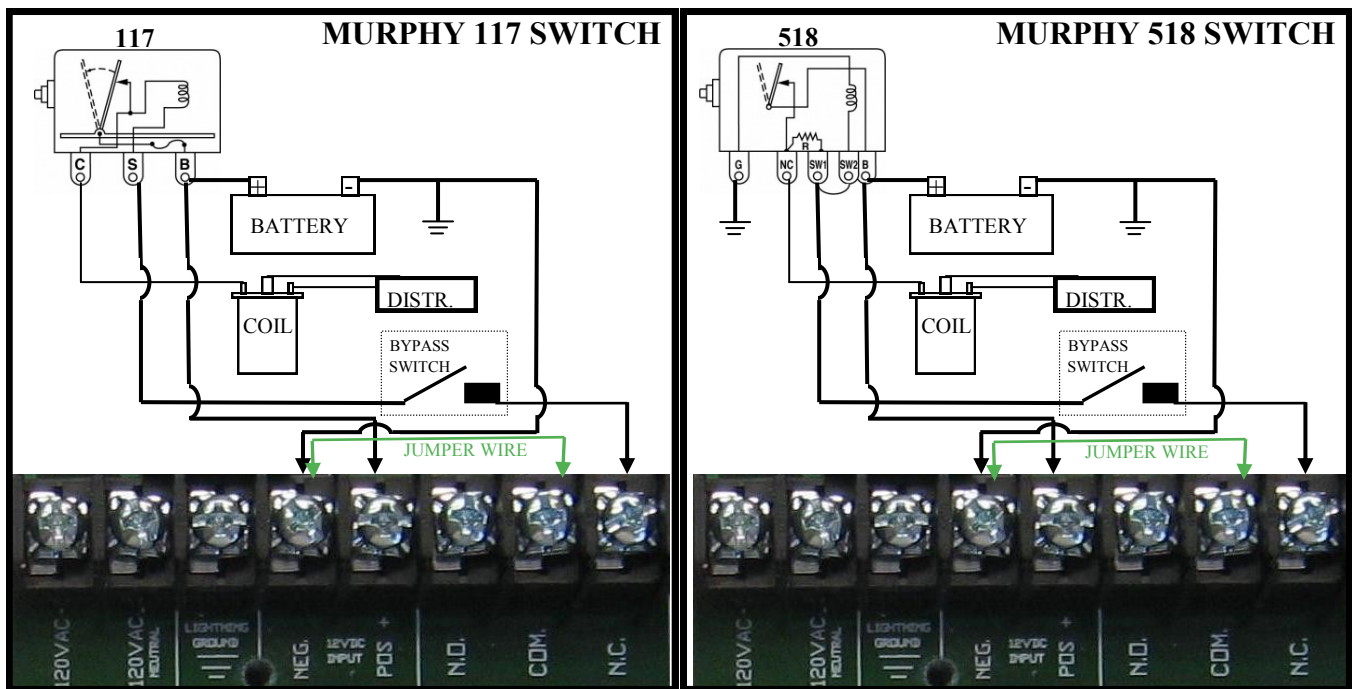

RECEIVER UNIT 810-3R

CAUTION: Never switch any voltage greater than 120v with the Hot Shot Receivers internal relays. This will ruin the relay and void all manufacturer warranties. Use an externally mounted 120v coil relay to switch all voltages greater than 120v. See diagram on next page.

HOT SHOT RECEIVERS NEED TO BE TURNED ON BEFORE THE HOT SHOT TRANSMITTERS ARE TURNED ON. HOT SHOT TRANSMITTERS ONLY TRANSMIT FOR 1 MINUTE. IF THE RECEIVER IS TURNED ON AFTER THE TRANSMITTER IT WILL NOT OPERATE CORRECTLY UNTIL THE TRANSMITTER IS SET TO TRANSMIT AGAIN.

ELECTRIC WELL HOOKUP

- Mount a 480v-120v step-down transformer to supply 120v to the receiver. The Hot Shot Receiver only requires 1 watt of power to operate. *Hot Shot Systems suggest using a minimum of a single phase 60 hertz 0.050kVA transformer. They are available for purchase through Hot Shot Systems, just request when ordering.*
- Mount a 3 terminal fuse block and a 120vac relay. *Hot Shot Systems suggest using a 115V AC coil relay. They are available for purchase through Hot Shot Systems, just request when ordering.*
- Wire two, 480v conductors through the first two fuses (1/2 or 1 amp each) to the primary side of the step-down transformer. **Terminals may be different according to the transformer installed.**
- Wire the 120v **X1** terminal of the step-down transformer through the remaining fuse (1 amp) which then goes to the first 120vac input of the Hot Shot Receiver (120 volt polarity does not matter).
- Wire the 120v **X2** terminal of the step-down transformer to the neutral 120vac input of the Hot Shot Receiver (see diagram on the next page).
- Add a jumper from the first 120vac terminal to the Hot Shot Receivers relay **COM.** terminal (see diagram on the next page).
- Wire the **NO.** terminal on the Hot Shot Receiver to one side of the 120v relay coil.
- Connect the other side of the relay coil to the **X2** terminal of the step-down transformer.
- Connect a wire from the **Lighting Ground** terminal of the Hot Shot Receiver to the ground lug of the pump panel.

RECEIVER UNIT 810-3R

ELECTRIC WELL HOOKUP DIAGRAM

OBJECT: WHEN THE HOT SHOT TRANSMITTER'S RELAY INPUT TO COMMON IS CLOSED IT SENDS OUT THE RELAY ON COMMAND TO THE RECEIVER. WHEN THE HOT SHOT RECEIVER GETS THE ON SIGNAL IT WILL CLOSE ITS NO TO COMMON CONTACTS. THIS WILL ENERGIZE THE 120V RELAY TO CLOSE THE 480V CONTACTOR.

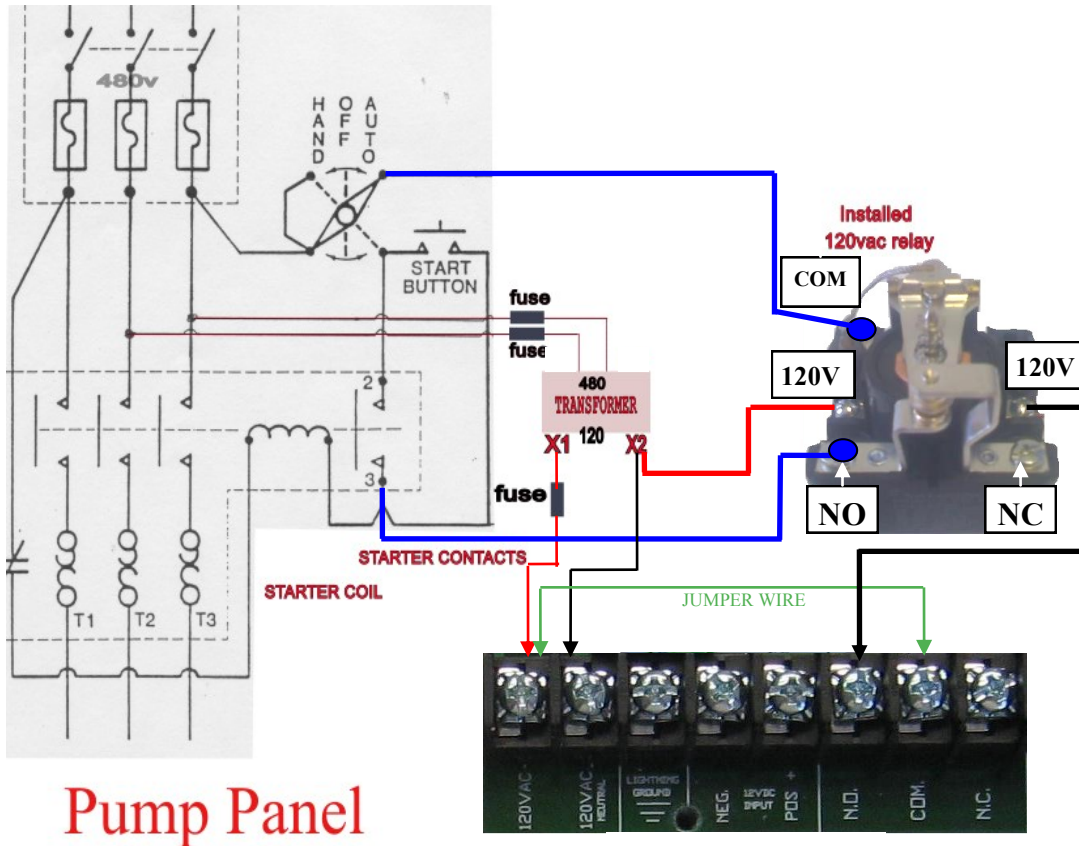

Pump Panel

RECEIVER UNIT 810-3R

NOTE: This equipment has been tested and found to comply with the limits for a Class B digital device, pursuant to part 15 of the FCC Rules. These limits are designed to provide reasonable protection against harmful interference in a residential installation. This equipment generates, uses and can radiate radio frequency energy and, if not installed and used in accordance with the instructions, may cause harmful interference to radio communications. However, there is no guarantee that interference will not occur in a particular installation. If this equipment does cause harmful interference to radio or television reception, which can be determined by turning the equipment off and on, the user is encouraged to try to correct the interference by one or more of the following measures:

- Reorient or relocate the receiving antenna.
- Increase the separation between the equipment and receiver.
- Connect the equipment into an outlet on a circuit different from that to which the receiver is connected.
- Consult the dealer or an experienced radio/TV technician for help.

15.21 INFORMATION to USER:

The users manual or instruction manual for an intentional or unintentional radiator shall caution the user that changes or modifications not expressly approved by the party responsible for compliance could void the user's authority to operate the equipment.