

HOT SHOT

IRRIGATION

810-3T

TRANSMITTER GUIDE

Pg.

2	HOT SHOT OVERVIEW
3	STANDARD OPERATION MODE
4	TRANSMITTER FUNCTION SWITCH SETTINGS
5	MULTI PIVOT APPLICATIONS
5	MULTI WELL APPLICATIONS
5	REINKE PIVOTS
6	VALLEY 4000, 6000, AND PANELS WITH 3 SEC DELAY PCB.
7	VALLEY 8000, PRO PANEL, SELECT PANEL AND SIMILAR
8	T-L ELECTRIC PANEL
9	T-L ENGINE PIVOT (ISUZU PANEL)
10	ZIMMATIC PIVOT

HOT SHOT OVERVIEW

CAUTION: Never connect any voltage to the HOT SHOT Relay Input terminals. The Hot Shot supplies the voltage needed for sensor switching (use dry relay contacts only). Make sure the pivot's well kill terminals do not have voltage from previously wired configurations.

ATTENTION: Depending upon the style of system that your are going to control with the Hot Shot Wireless Controller you may need to supply additional parts. Such as relays, step-down transformers, Murphy switches etc. These items are suggested in the wiring guides that follow in this manual.

HOW IT WORKS

Think of the HOT SHOT system as a 12-2 control wire going from the pivot to the irrigation pump. When the Hot Shot Transmitter's RELAY Input is activated, a 15 second delay timer is started. After the delay timer has expired, the transmitter will send the (turn ON) command to the receiver. This transmission will close the relay contacts at the pump to start water. When the pivot is done irrigating or when the safety is tripped, the pivot will open the Hot Shot Transmitter's RELAY Input contacts and send the (turn OFF) relay command to stop water. Battery backup in the transmitter will still allow the HOT SHOT to work in case of a pivot power outage. Each system is coded with its own four digit code so it will not interfere with other systems in the same area. The following manual has been prepared to provide details for Transmitter installation and Receiver installation on electric and engine driven wells.

MOUNTING























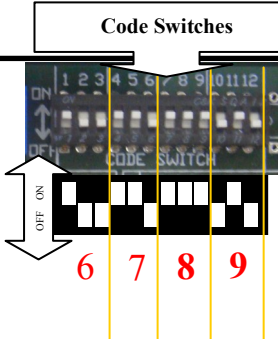

Cabinets are a weatherproof UV protected NEMA 4X cabinet with mounting ears on top and bottom. The transmitter/receiver control box can be mounted on the side of a control panel, pole or any other surface as long as the antenna does not have metal running within 12" of the antenna whip. If longer range is needed, an external long range antenna can be used. Do not mount the HOT SHOT receiver to the well engine or cover because the strong vibrations can be harmful to the unit.

CODE SWITCH SETTINGS

All transmitters and receivers will be shipped from the factory with preprogrammed field codes. This ensures that your neighbor will not duplicate the same field code as your unit. Your field codes already match, so you do not need to program any codes. If you ever need to replace a unit due to servicing, the field code can be programmed to match the existing or new add on units. FOLLOW THE EXAMPLE BELOW...

FOR CODE QUESTIONS? CALL 785-623-1500

EXAMPLE: CODE 6789

<p>KEY</p> <table border="0" style="width: 100%;"><tr><td style="text-align: center;">3</td><td style="text-align: center;">4</td><td style="text-align: center;">5</td><td style="text-align: center;">6</td></tr><tr><td style="text-align: center;"></td><td style="text-align: center;"></td><td style="text-align: center;"></td><td style="text-align: center;"></td></tr><tr><td style="text-align: center;">7</td><td style="text-align: center;">8</td><td style="text-align: center;">9</td><td style="text-align: center;">0</td></tr><tr><td style="text-align: center;"></td><td style="text-align: center;"></td><td style="text-align: center;"></td><td style="text-align: center;"></td></tr></table>	3	4	5	6					7	8	9	0					<p>Use the # KEY to the left to make each digit of the code. It takes three of the switches to make one number of the code.</p> <p>Use switches 1,2,3 for the first # in the code. Switches 4,5,6 for the second #. Switches 7,8,9 for the third #. Switches 10,11,12 for the fourth #.</p>	<p>Code Switches</p> 
3	4	5	6															
																		
7	8	9	0															
																		

BATTERY BACKUP

During a power outage, a gel cell rechargeable battery will supply power to the transmitter for approximately 24 hours. This will allow the transmitter to send a shutdown signal to the receivers when the pivot has lost power. The Hot Shot Transmitter comes with a battery saver feature that will turn off the Hot Shot Transmitter if the voltage drops from 12vdc to 10vdc. This function will add years of life to the gel cell battery.

Important... When the battery has discharged, it will take approximately 15 to 20 minutes for the battery to charge enough to operate the transmitter in case of another power failure. The battery should be replaced every year for the best reliability during power outages. Call 785-623-1500 for replacement batteries.

TRANSMITTER UNIT 810-3T

STANDARD OPERATION MODE

The Standard Operation Mode is the default mode for all transmitters. Most pivot installations will use this method because they only have a single throw relay in their panel. (*Single throw relays only have a COM and NO contact.*) In Standard Operation Mode Function Switches 1-8 need to all be turned OFF. Standard Operation Mode only uses the **RELAY ON** side of the relay inputs on the transmitter. When there is contact made between **RELAY ON** and **COMMON** (*when requesting water*) the transmitter will send out the ON code to the receiver. When contact is opened between **RELAY ON** and **COMMON** (*such as when the pivot is finished or stop water*) the transmitter will send out the OFF code. See the diagrams below. Brand specific instructions are shown later in the wiring diagrams.

Shown in the diagrams below is a generic diagram of how to wire a pivot panel to the Hot Shot Transmitter using the Standard Operating Mode. This style is used for one pivot with one well or one pivot with multiple wells that will always operate at the same time. It can also be used with multiple pivots sharing one well or multiple wells as long as only 1 pivot is operating at a time and the other transmitters are switched OFF. The wiring for each transmitter is the same.

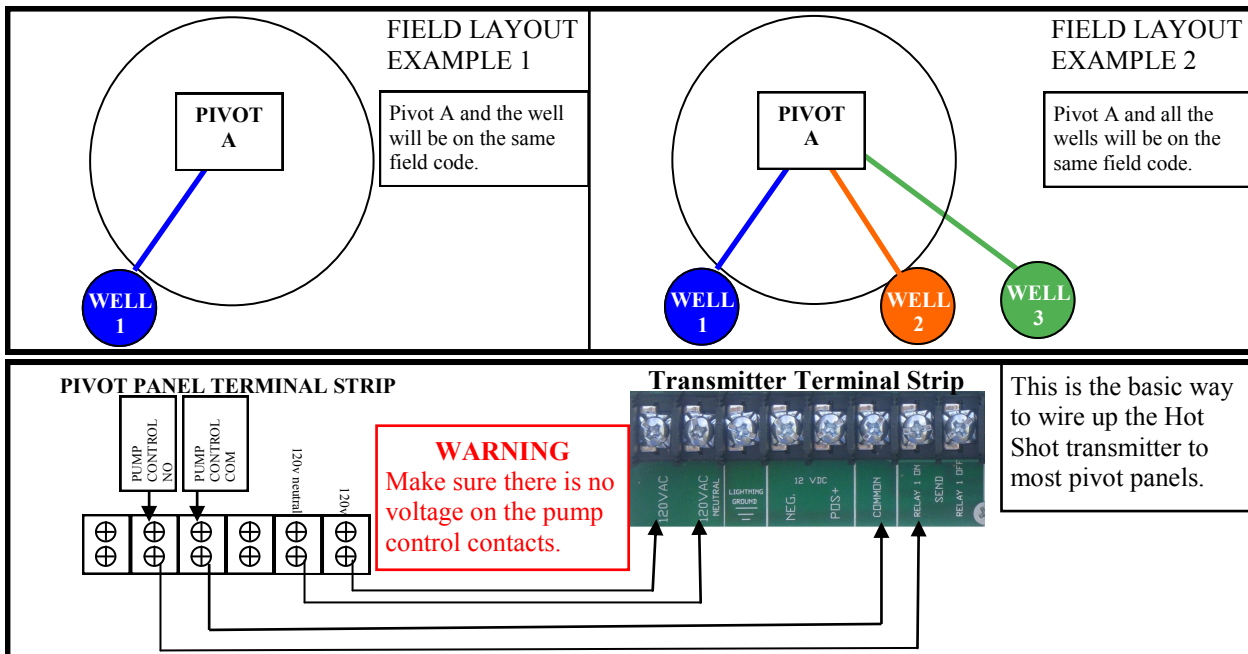

DISCRETE OPERATION MODE

The Discrete Operation Mode is used with a single pole double throw relay in the pivot panel and for irrigation systems that require more intricate pump control operations. It is most often used with the 810-3T-PLUS transmitter and the Pump Selector Kit. Please refer to the website hotshotsystems.com or call us at 785-623-1500 for more information. **For Discrete Operation Mode to work the FUNCTION SWITCH for each RELAY Input must be turned ON.** Function Switch 1 for RELAY 1 inputs, Function Switch 2 for RELAY 2 inputs and Function Switch 3 for RELAY 3 inputs. Once these switches are turned on the transmitter will have to see a connection from any of the RELAY inputs to COMMON before it will transmit any signals. Simply removing the connection from RELAY ON to COMMON will not shut the pump down it must have a connection from RELAY OFF to COMMON for the transmitter to send a signal to the receiver to shut off the pump.

TRANSMITTER UNIT 810-3T

TRANSMITTER FUNCTION SWITCH SETTINGS

SWITCH#

1	ON	SENSOR 1 DISCRETE OPERATING MODE (see page #4)
	OFF	SENSOR 1 STANDARD OPERATING MODE (see page #4)
2	ON	SENSOR 2 DISCRETE OPERATING MODE (see page #4)
	OFF	SENSOR 2 STANDARD OPERATING MODE (see page #4)
3	ON	SENSOR 3 DISCRETE OPERATING MODE (see page #4)
	OFF	SENSOR 3 STANDARD OPERATING MODE (see page #4)
4-7 NOT USED		
8	ON	ACTIVATES THE TEST BEACON (Used for testing and range finding only. When activated the transmitter will send a code every 10sec cycling the receivers relay. To activate this feature put a jumper wire from the RELAY ON to COMMON on the relay input you want to test. DO NOT have the receiver wired to the pump during this test. This function must be turned off for normal operation. See description at the bottom of this page.)
	OFF	NORMAL OPERATION MODE
9	ON	REFRESH (This function will retransmit the code once every hour.)
	OFF	NO REFRESH (Transmits the code only when there is a change of state on the Relay Inputs.)

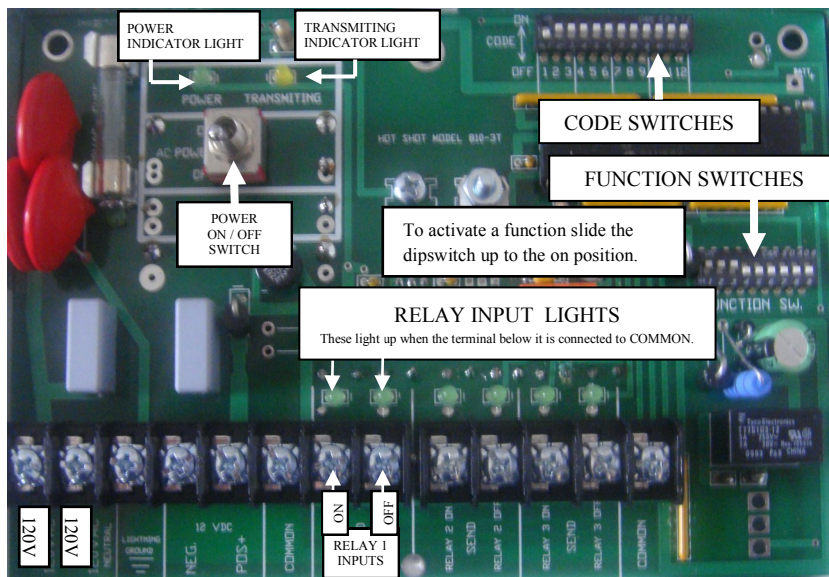

OPERATING THE TEST BEACON

The Test Beacon function is turned on and off by using FUNCTION SWITCH #8 (see above). **This feature is used for testing and range finding purposes only.** To activate the Test Beacon first turn OFF the power to the transmitter. Turn function switch #8 on and connect a small jumper wire from the **RELAY 1 ON** terminal to the **COMMON** terminal and then turn the power back ON to the transmitter. *See diagram below.* When turned ON the Transmitting Light will blink and the code will be transmitted every 10 seconds cycling the receiver's relay.

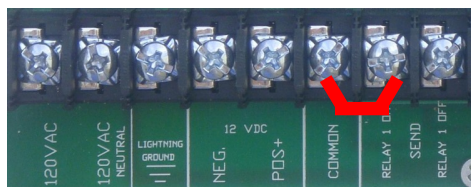

Trans Terminal Strip

DO NOT have the receiver wired up to the pump during this procedure because it will continually open the relay for 10 seconds and then close the relay for 10 seconds causing damage to the pump. **Function switch #8 must be turned OFF and the jumper wire removed for the transmitter to operate normally.**

MULTI PIVOT APPLICATIONS

A Hot Shot System can be made up with multiple pivots running on the same well. Each pivot will need its own transmitter to control the one receiver at the well. All transmitters and the receiver will be on the same code and the transmitters will all be in Standard Operation Mode with well control wires from the pivot panel going to the RELAY 1 ON terminal and the COMMON terminal on the transmitter. When using multiple pivots on the same pump, you can shut down one pivot without affecting the operation of the well pump and other pivots. This can be done with the ON-OFF switch that is mounted on the transmitter. Switching it to OFF will allow the pivot to be manually taken out of service and will stop all radio transmissions from that pivot. **Just turning off the power to the pivot will not shut off the Hot Shot Transmitter because of its battery backup.** You must turn the Hot Shot Transmitter off so that it will not try to shutdown the well while another pivot is trying to use it.

MULTI WELL APPLICATIONS

A Hot Shot System can be made up with one pivot controlling multiple wells. This can be done as simply as using the Standard Operation Mode and wiring up the well control wires to the RELAY 1 ON input and COMMON on the transmitter. Then letting it control as many wells as you need. This mode can also be used with the **PUMP SELECTOR KIT** when wanting to select an individual well or a group of wells for different operations however these wells can not be shared with another pivot. If the wells are shared you will need to use the **DISCRETE OPERATION MODE**. Please refer to the website hotshotsystems.com or call us at 785-623-1500 for more information.

REINKE PIVOTS

WIRING INSTRUCTIONS FOR STANDARD OPERATION MODE

FIRST make sure all the function switches on the transmitter are in the correct position for this style of operation. See Standard Operation Mode on page 3.

To supply the 120v needed for the Hot Shot Transmitter to operate, run a wire from the pivot panel's 120v fuse block through an inline fuse holder with a 1.5 amp fuse to the first 120v input on the transmitter. Run another wire from the pivot panel's neutral terminal (usually #J9) to the second 120v input (neutral) on the transmitter.

Make sure the pivot's well kill terminals DO NOT have any voltage from previously wired configurations. Run a wire from terminal #J12 to the Hot Shot Transmitter's COMMON input. Run a wire from terminal #J11 to the Hot Shot Transmitter's RELAY ON input. See diagram A below.

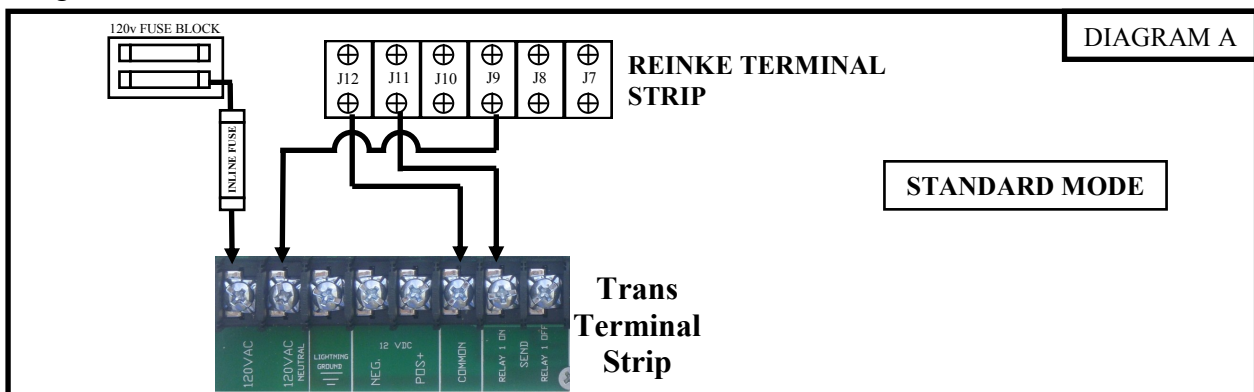

VALLEY MODELS

4000, 6000, & PANELS WITH 3 SEC DELAY PCB.

WIRING INSTRUCTIONS FOR STANDARD OPERATION MODE

FIRST make sure all the function switches on the transmitter are in the correct position for this style of operation. See Standard Operation Mode on page 3.

To supply the 120v needed for the Hot Shot Transmitter to operate run a wire from the pivot panels 120v fuse block through a inline fuse holder (Valley part #1811175) with a 1 1/2 amp fuse to the first 120v input on the transmitter. Run another wire from the pivot panels neutral terminal (usually wired with white wires) to the second 120v input (neutral) on the transmitter.

With these models we recommend that you use terminal #3, #4 and #5 on the 3 Sec Delay PCB to control the Hot Shot Transmitter. Remove the wires that currently go into them and cap them off. Run a wire from terminal #3(NO) on the 3 Sec Delay PCB to the RELAY ON input on the transmitter. Run a wire from terminal #4(COM) on the 3 Sec Delay PCB to the COMMON input on the transmitter. See diagram below. Terminal #5 is only used for DIS-CRETE MODE. When needing to move the pivot with out turning on the pump simply flip the Hot Shot Transmitter's power switch to OFF then power up the pivot and move it.

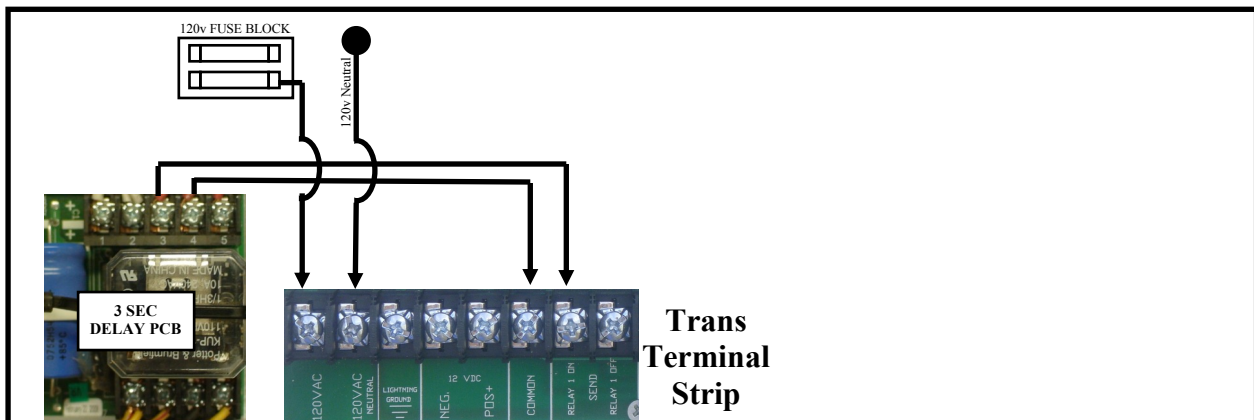

VALLEY MODELS

8000, PRO PANEL, SELECT PANEL & SIMILAR

WIRING INSTRUCTIONS FOR STANDARD OPERATION MODE

FIRST make sure all to function switches on the transmitter are in the correct position for this style of operation. See Standard Operation Mode on page 3.

To supply the 120v needed for the Hot Shot Transmitter to operate run a wire from the pivot panels terminal #3 through a inline fuse holder (Valley part #1811175) with a 1 1/2 amp fuse to the first 120v input on the transmitter. Run another wire from the pivot panels terminal #9 or #10 (CONTROL NEUTRAL) to the second 120v input on the transmitter.

To connect the panels well control relay to the Hot Shot Transmitter run a wire from terminal #15 (PUMP CONTROL NO) to the transmitters RELAY ON input. Now run a wire from terminal #16 (PUMP CONTROL COMMON) to one of the transmitters COMMON inputs. See diagram below. When needing to move the pivot with out turning on the pump simply flip the Hot Shot Transmitter's power switch to OFF then power up the pivot and move it.

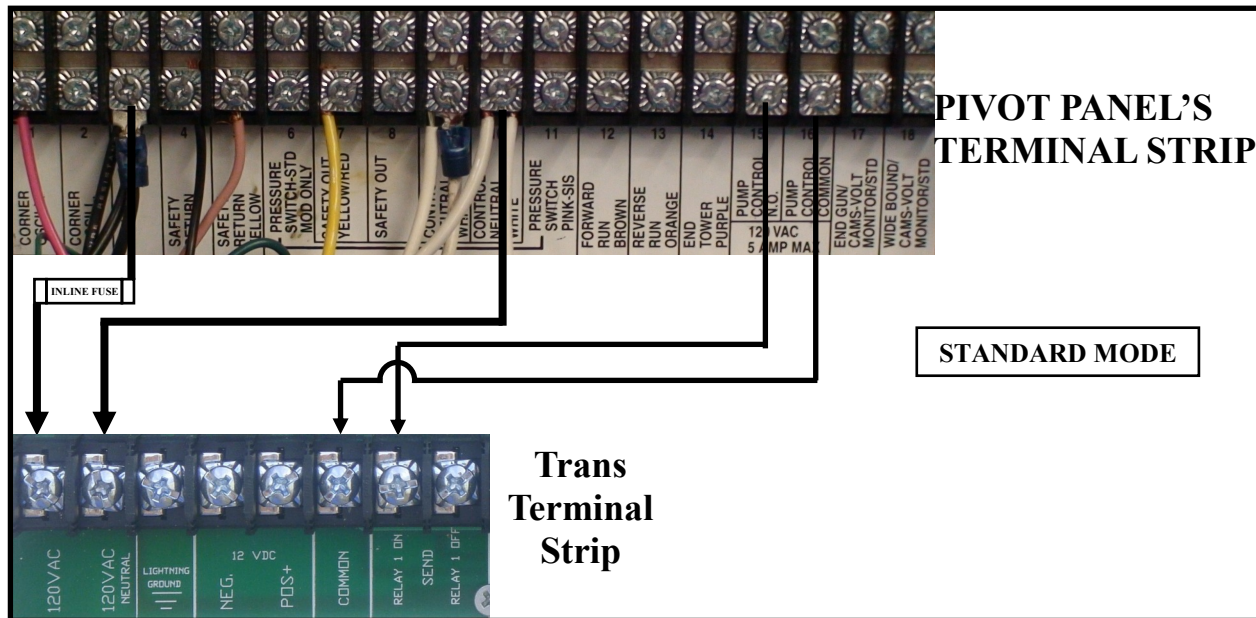

T-L ELECTRIC PANEL

WIRING INSTRUCTIONS FOR STANDARD OPERATION MODE

FIRST make sure all the function switches on the transmitter are in the correct position for this style of operation. See Standard Operation Mode on page 3.

To supply the 120v needed for the Hot Shot Transmitter to operate, install a 24VAC to 120VAC step up transformer. These are available to purchase from Hot Shot Systems. Run two wires from the 24 VAC transformer through inline fuse's (at least 5 amp) to the 24VAC to 120VAC step up transformer. Then take the 2 wires from the 120VAC side and run them to the transmitters two 120V inputs. **INSTALL** a Hot Shot 24vac relay or a T-L 24VAC Interface Relay (Relay Part#EC52201 Base Part#EC53152) to control the RELAY inputs on the transmitter. Power the Interface Relay by running a wire from the pivot panels Water Pump Control terminals (terminal #1 and #2) to each side of the Interface Relays coil terminals. Run a wire to connect the COM terminal on the 24vac Relay to the COM input on the transmitter. Wire up the NO terminal on the 24vac Relay to the RELAY ON on the Transmitter. See below.

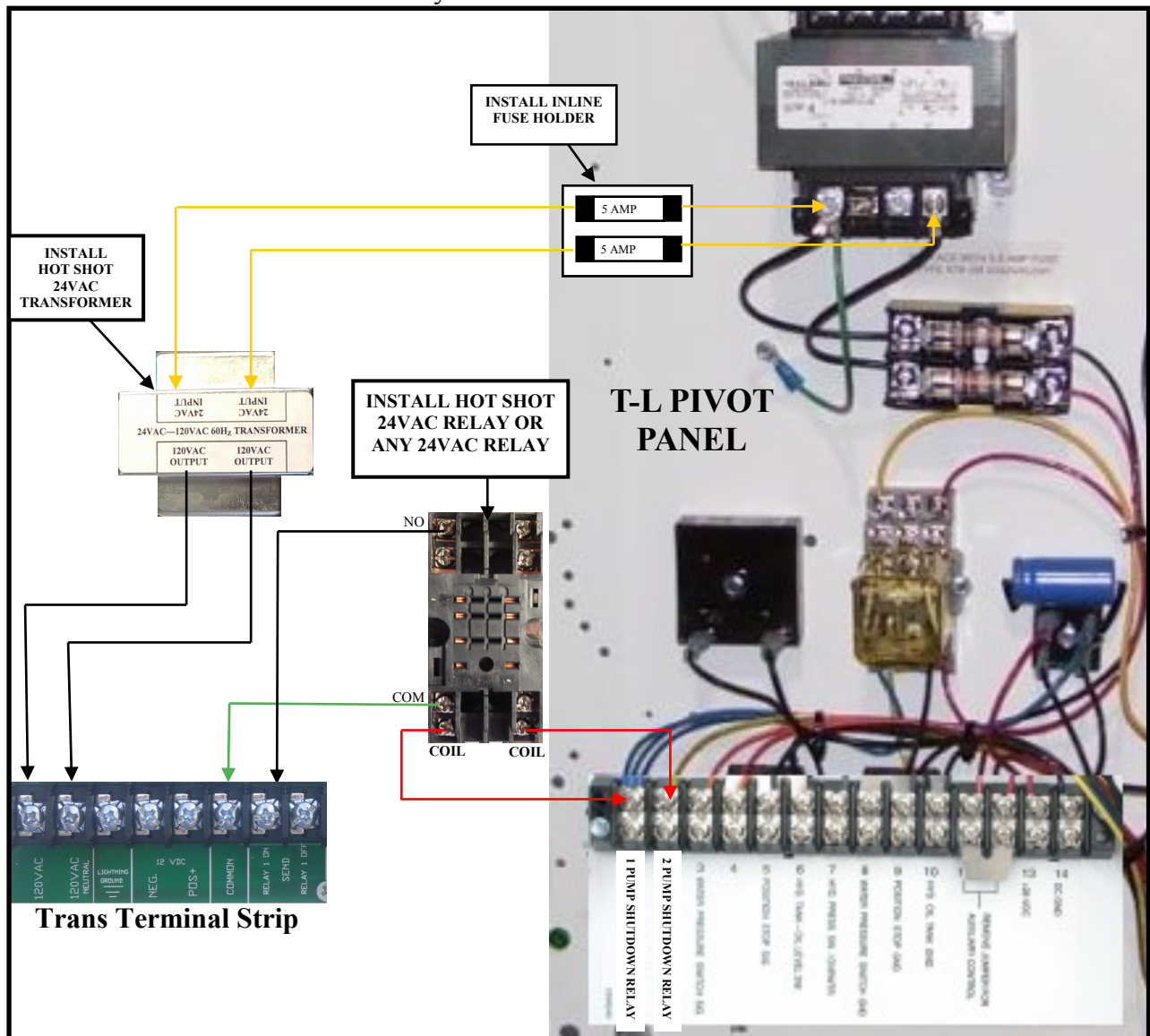

T-L ENGINE PIVOT (ISUZU PANEL)

WIRING INSTRUCTIONS FOR STANDARD OPERATION MODE

FIRST make sure all the function switches on the transmitter are in the correct position for this style of operation. See Standard Operation Mode on page 3.

Run a wire from the +12v dc terminal on the pivot panels terminal strip (usually terminal #4 or #5) to the +12v dc input on the transmitter. Run a wire from the pivot panels Ground Strip to the NEG input on the transmitter. Now install a T-L 12v dc Interface Relay (part# EC52125) to control the RELAY inputs on the transmitter. To control the 12v Interface Relay run a wire from the pivot panels terminal #12 to one side of the relays coil terminals. Run another wire from the pivot panels ground strip to the other coil terminal on the T-L 12v Interface Relay. Now run a wire from the T-L 12v Interface Relay's NO terminal to the RELAY ON input on the transmitter. Run another wire from the 12v Interface Relay's COM terminal to one of the COMMON inputs on the transmitter. See diagram below.

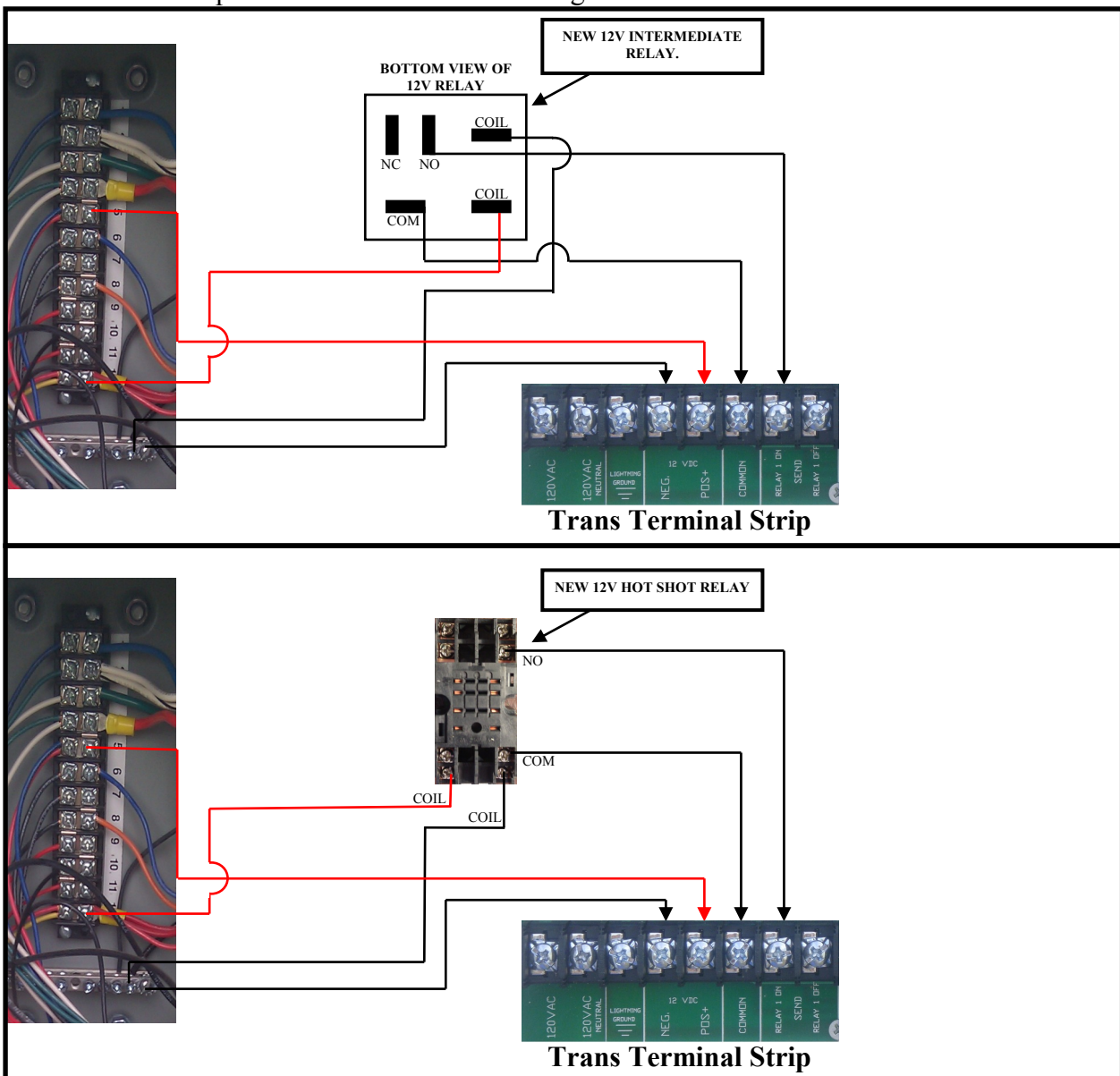

ZIMMATIC PIVOTS

WIRING INSTRUCTIONS FOR STANDARD OPERATION MODE

FIRST make sure all the function switches on the transmitter are in the correct position for this style of operation. See Standard Operation Mode on page 3.

To supply the 120v needed for the Hot Shot Transmitter to operate run a wire from the pivot panels 120v X3 terminal through a inline fuse holder with at least a 1 1/2 amp fuse to the first 120v input on the transmitter. Run another wire from the 120v X1 terminal through a inline fuse holder with at least a 1 1/2 amp fuse to the second 120v input on the transmitter. Install a Zimmatic 24vac relay in the panel (part# 09-88907). Wire one side of the relay coil to terminal #65 and connect the other side of the relay coil to terminal #4. Wire the N.O. side of the 24v relay to the RELAY ON input on the transmitter. Wire the COM terminal of the 24v relay to the COMMON input on the transmitter. See diagram below.

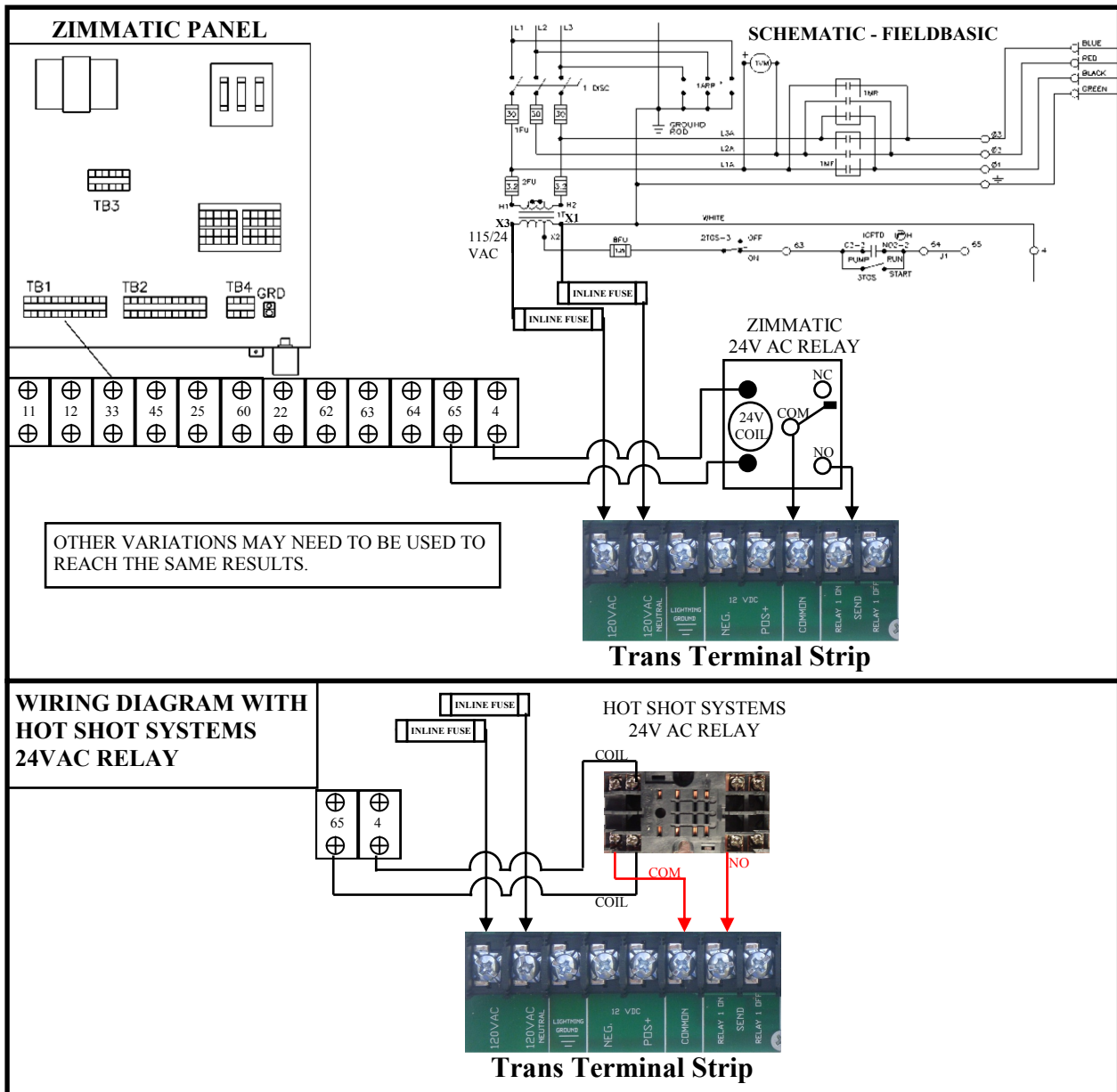

TRANSMITTER UNIT 810-3T

NOTE: This equipment has been tested and found to comply with the limits for a Class B digital device, pursuant to part 15 of the FCC Rules. These limits are designed to provide reasonable protection against harmful interference in a residential installation. This equipment generates, uses and can radiate radio frequency energy and, if not installed and used in accordance with the instructions, may cause harmful interference to radio communications. However, there is no guarantee that interference will not occur in a particular installation. If this equipment does cause harmful interference to radio or television reception, which can be determined by turning the equipment off and on, the user is encouraged to try to correct the interference by one or more of the following measures:

- Reorient or relocate the receiving antenna.
- Increase the separation between the equipment and receiver.
- Connect the equipment into an outlet on a circuit different from that to which the receiver is connected.
- Consult the dealer or an experienced radio/TV technician for help.

15.21 INFORMATION to USER:

The users manual or instruction manual for an intentional or unintentional radiator shall caution the user that changes or modifications not expressly approved by the party responsible for compliance could void the user's authority to operate the equipment.

