

# **HOT SHOT**

## **SHUTDOWN SYSTEM GUIDE**

*Pg.*

<b>2</b>	<b>HOT SHOT OVERVIEW</b>
<b>3</b>	<b>TRANSMITTER FUNCTION SWITCH SETTINGS</b>
<b>3</b>	<b>TRANSMITTER TEST SWITCH</b>
<b>4</b>	<b>SHUTDOWN MODE</b>
<b>5</b>	<b>CONTROL MODE</b>
<b>6</b>	<b>RECEIVER FUNCTION SWITCH SETTINGS</b>
<b>7</b>	<b>RECEIVER INDICATOR LIGHTS</b>
<b>7</b>	<b>SUPERVISION / SUPERVISION FAIL-SAFE FEATURES</b>
<b>8</b>	<b>RECEIVER HOOKUP TO ELECTRIC WELL</b>
<b>9</b>	<b>RECEIVER HOOKUP TO ELECTRIC WELL DIAGRAM</b>
<b>10</b>	<b>RECEIVER HOOKUP TO ENGINE DRIVEN WELL</b>

# HOT SHOT OVERVIEW

**ATTENTION:** Depending upon the style of system that your are going to control with the Hot Shot Wireless Controller you may need to supply additional parts. Such as relays, step-down transformers, floats, sensors, Murphy switches etc. These items are suggested in the wiring guides that follow in this manual.

## HOW IT WORKS

Think of the HOT SHOT system as a 12-2 control wire going from the tank to the pump. When the Hot Shot Transmitter's RELAY Input is activated, it gets a closure from the fluid sensor or float, a 15 second delay timer is started (this makes sure it a steady read and not a false read from ripples etc). If the fluid sensor or float is still closed after the 15 second delay a shutdown command is sent to the receiver at the pump or pumps. At the receiver the shutdown signal will latch a relay and remove voltage from the motor relay. The receiver will stay latched until the manual reset button is pushed or a reset signal has been sent by the transmitter. Battery backup in the transmitter will still allow the HOT SHOT to work in case of a power outage. Each system is coded with its own four digit code so it will not interfere with other systems in the same area. The following manual has been prepared to provide details for Transmitter installation and Receiver installation on electric and engine driven pumps.

## MOUNTING

Cabinets are a weatherproof UV protected NEMA 4X cabinet with mounting ears on top and bottom. The transmitter control box can be mounted on the side of a control panel, pole or any other surface as long as the antenna does not have metal running within 12" of the antenna whip. If longer range is needed, an external long range antenna can be used. Do not mount the HOT SHOT receiver to the well engine or cover because the strong vibrations can be harmful to unit.

## CODE SWITCH SETTINGS

All transmitters and receivers will be shipped from the factory with preprogrammed field codes. This ensures that your neighbor will not duplicate the same field code as your unit. Your field codes already match, so you do not need to program any codes. If you ever need to replace a unit due to servicing, the field code can be programmed to match the existing or new add on units. To do this, FOLLOW THE EXAMPLE BELOW...

FOR CODE QUESTIONS? CALL 785-623-1500

**Transmitter Code Switches**

**EXAMPLE: CODE 6789**

<p><b>KEY</b></p> <table border="0" style="width: 100%;"><tr><td style="text-align: center;">3</td><td style="text-align: center;">4</td><td style="text-align: center;">5</td><td style="text-align: center;">6</td></tr><tr><td style="text-align: center;">7</td><td style="text-align: center;">8</td><td style="text-align: center;">9</td><td style="text-align: center;">0</td></tr></table>	3	4	5	6	7	8	9	0	<p>Use the # KEY to the left to make each digit of the code. It takes three of the switches to make one number of the code.</p>	<p>Use switches 1,2,3 for the first # in the code. Switches 4,5,6 for the second #. Switches 7,8,9 for the third #. Switches 10,11,12 for the fourth #.</p>
3	4	5	6							
7	8	9	0							

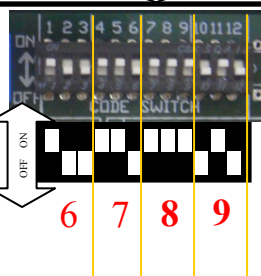

## BATTERY BACKUP

During a power outage, a gel cell rechargeable battery will supply power to the transmitter for approximately 24 hours. This will allow the transmitter to send a shutdown signal to the receivers if it has lost power. The Hot Shot Transmitter comes with a battery saver feature that will turn off the Hot Shot Transmitter if the voltage drops from 12vdc to 10vdc. This function will add years of life to the gel cell battery.

**Important...** When the battery has discharged, it will take approximately 15 to 20 minutes for the battery to charge enough to operate the transmitter in case of another power failure. The battery should be replaced every year for the best reliability during power outages. Call 785-623-1500 for replacement batteries.

# TRANSMITTER UNIT 810-3T

## HOT SHOT TRANSMITTER

**CAUTION:** Never connect any voltage to the HOT SHOT Relay Input terminals. The Hot Shot supplies the voltage needed for sensor switching (**use dry relay contacts only**). Make sure the float or sensor terminals do not have voltage from previously wired configurations.

### TRANSMITTER FUNCTION SWITCH SETTINGS

SWITCH#

1	<b>ON</b>	RELAY 1 SHUTDOWN MODE (see page #4)	
	<b>OFF</b>	RELAY 1 CONTROL MODE (see page #5)	
2	<b>ON</b>	RELAY 2 SHUTDOWN MODE (see page #4)	← EXTRA OPTION
	<b>OFF</b>	RELAY 2 CONTROL MODE (see page #5)	
3	<b>ON</b>	RELAY 3 SHUTDOWN MODE (see page #4)	← EXTRA OPTION
	<b>OFF</b>	RELAY 3 CONTROL MODE (see page #5)	
4-7	<b>NOT USED</b>		
8	<b>ON</b>	ACTIVATES THE TEST BEACON (Used for testing and range finding only. When activated the transmitter will send a code every 10sec cycling the receivers relay. DO NOT have the receiver wired to the pump during this test. This function must be turned off for standard operation.)	
	<b>OFF</b>	NORMAL OPERATION MODE	
9	<b>ON</b>	REFRESH (This function ONLY works in CONTROL MODE, it will retransmit the code once every 45 MINUTES.)	
	<b>OFF</b>	NO REFRESH (Transmits the code only when there is a change of state on the Relay Inputs.)	

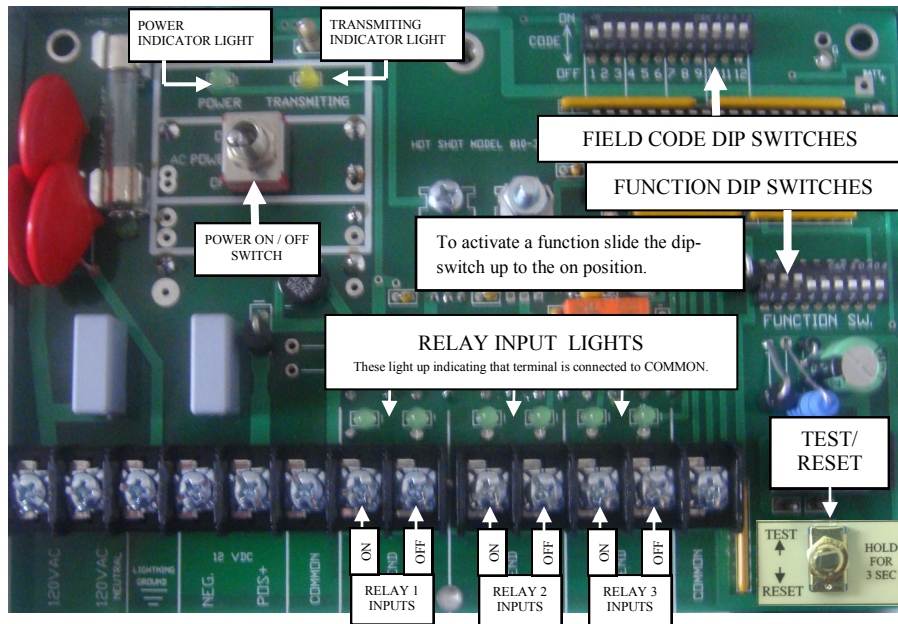

### TEST SWITCH

The test switch is used for a quick test of the systems integrity. For a complete system test you will need to activate the float or sensor and then see if all the receivers shutdown. Then use the reset side of the test switch to restart all the pumps. *Engine driven pumps may have to be restarted at the pump.*

**WARNING:** Resetting a pump jack remotely can be dangerous! Make sure it is in working order and that the area is clear of all people and animals before restarting the pump.

# TRANSMITTER UNIT 810-3T

## SHUTDOWN MODE

Shutdown mode is the most common used style for oil field shutdowns. It works with just a two wire control, such as a float or sensor that has normally open and common contacts. When the tank is full and the float comes up or the fluid sensor is activated there internal switch will close and make contact between the RELAY 1 ON input and the COMMON input on the transmitter. This will then send the relay on signal (*or shutdown signal*) to the receiver at the pump activating its relay to shutdown the pump. *See receiver wiring page #6.* The pump will then stay shutdown until it is either reset at the receiver or the reset is sent from the transmitter. *Engine driven pumps may have to be restarted at the pump.* See diagram below.

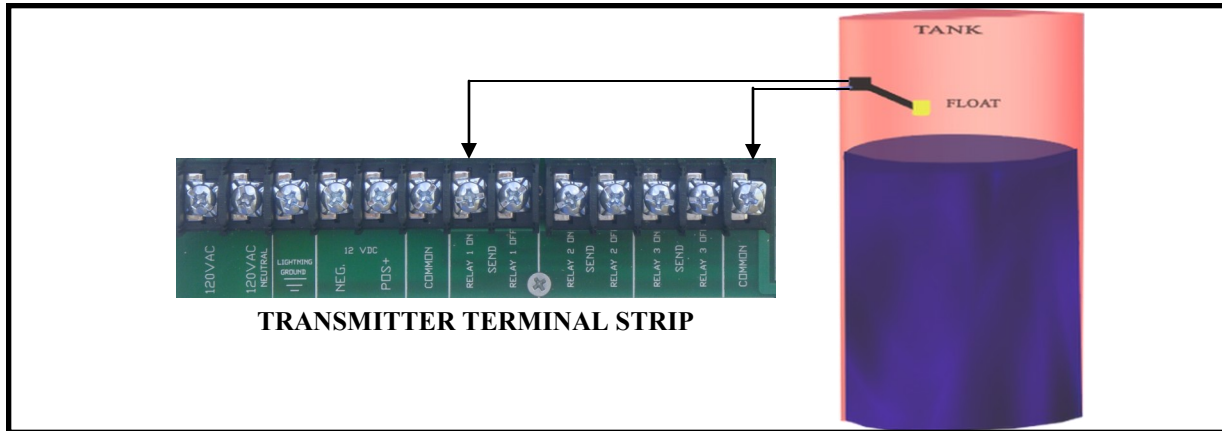

## SHUTDOWN MODE — EXTRA WIRING OPTION

Shutdown mode can also be used with a two float system. It works by wiring the top float into the RELAY 1 OFF input that when activated will shutdown the pump same as described above. Now by wiring a bottom float to the REALY 1 ON input and when it is activated (connected to COMMON) it will send the relay on command which will then activate the relay at the receiver allowing the pump to start. *Reverse wiring of the floats can be used for starting a pump when the tank is full and shutting off when the tank is empty.* See diagram below.

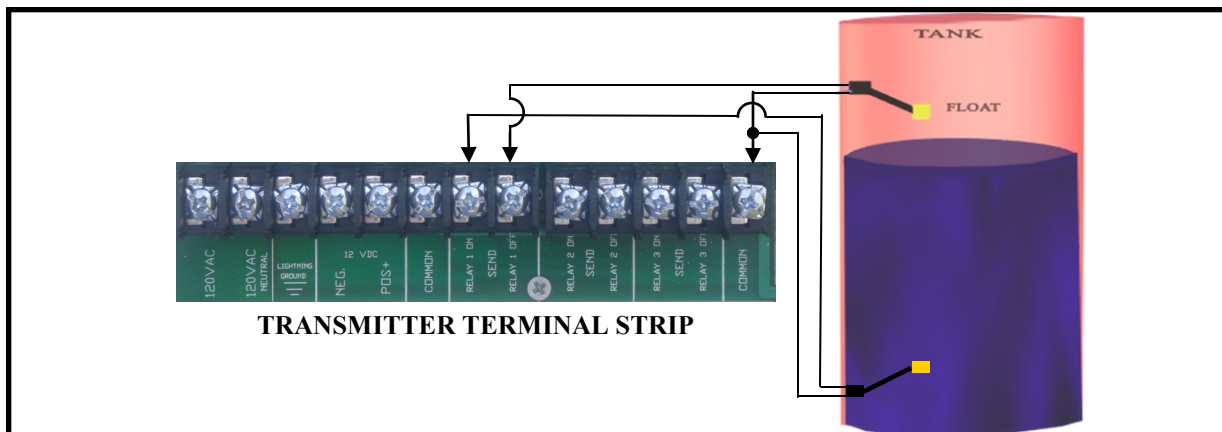

# TRANSMITTER UNIT 810-3T

## CONTROL MODE

Control mode is used more for water or fluid controls. It works with just a two wire control, such as a float or sensor that has normally open and common contacts. When the tank is full and the float comes up or the fluid sensor is activated there internal switch will close and make contact between the RELAY 1 ON input and the COMMON input on the transmitter. This will then send the relay on signal (*or shutdown signal*) to the receiver at the pump activating its relay to shutdown the pump. See receiver wiring page #6. When the tanks fluid level drops and the float drops or the sensor opens there internal switch will open and that will open the contact between RELAY 1 ON and COMMON inputs on the transmitter sending the relay off command which will then deactivate the relay at the receiver allowing the pump to start. See the diagrams below.

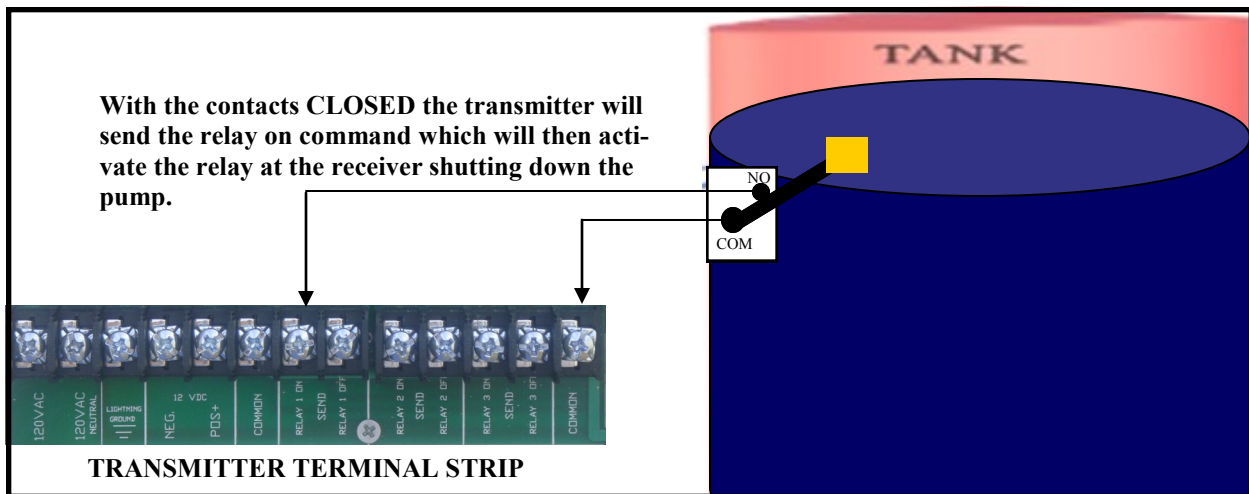
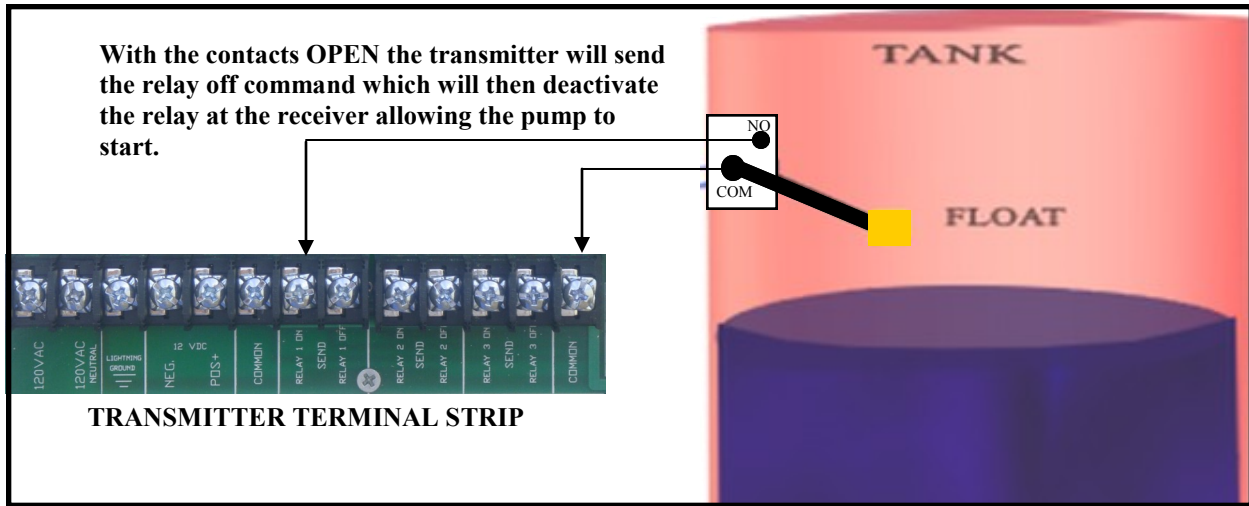

# RECEIVER UNIT 810-3R

## FUNCTION SWITCH SETTINGS

**SWITCH#**

**WHAT RELAY WILL DO WHEN ACTIVATED**

1	<b>ON</b>	WILL ACTIVATE MOMENTARY FOR 10 SEC. <i>This is used when shutting down an engine driven pump. It will ground out the Murphy kill switch for 10 sec than release. This will save on the battery by not having to hold the relay latched and allow the engine to be restarted when ready.</i>
	<b>OFF</b>	RELAY WILL STAY LATCHED UNTIL RESET CODE IS SENT.
2	<b>NOT USED</b>	
3	<b>ON</b>	ACTIVATION OF RELAY DELAYED BY 10 SEC. ( <b>NO DELAY ON SHUTDOWN.</b> ) <i>(SEE LOAD SHARING FEATURE) When turning on switch #3 and #4 it will create a 15 sec delay.</i>
	<b>OFF</b>	NO 10 SEC DELAY OF RELAY.
4	<b>ON</b>	ACTIVATION OF RELAY DELAYED BY 5 SEC. ( <b>NO DELAY ON SHUTDOWN.</b> ) <i>(SEE LOAD SHARING FEATURE) When turning on switch #3 and #4 it will create a 15 sec delay.</i>
	<b>OFF</b>	NO 10 SEC DELAY OF RELAY.
5-6	<b>NOT USED</b>	
7	<b>ON</b>	TURNS ON THE SUPERVISION FAIL SAFE <i>See Supervision Fail Safe page #7.</i>
	<b>OFF</b>	TURNS OFF THE SUPERVISION FAIL SAFE
8	<b>ON</b>	ACTIVATES THE SUPERVISION FEATURE <i>See Supervision Feature page #7.</i>
	<b>OFF</b>	DEACTIVATES THE SUPERVISION FEATURE
9	<b>NOT USED</b>	

**LOAD SHARING FEATURE - DIFFERENT DELAY TIMES CAN HELP WITH LARGE ELECTRICAL CURRENT PULLS IN THE SAME FIELD.**

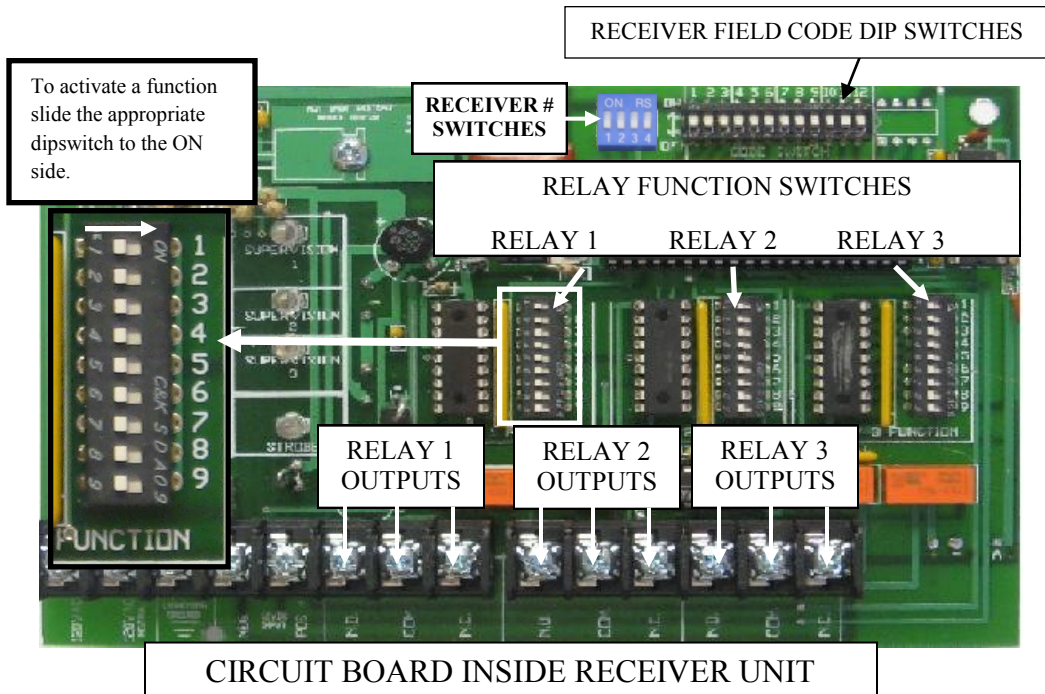

# RECEIVER UNIT 810-3R

## INDICATOR LIGHTS

- 1     **POWER**           Signals that the Receiver has power and is ready to receive the code from the Transmitter.
- 2     **STROBE**           Used for troubleshooting, this light flashes once for each of the four correct digits of the code received. The light will stay on steady for one second if an incorrect digit of the code is received. *Example: If the light flashes two times and then goes on steady it is indicating that the third digit doesn't match. If the light flashes one time and goes on steady it is indicating that the second digit doesn't match. If the light comes on steady right away it is indicating that the first digit doesn't match.*
- 3     **RELAY**            When this light is on it indicates that its corresponding relay has been activated.
- 4     **SUPERVISION**   When this light is flashing it indicates that it has not received its correct code from the transmitter in the past 3hrs. Sliding function switch #8 to its OFF position will turn off this indicator light. If the light is on steady than it has activated it Supervision Fail Safe.

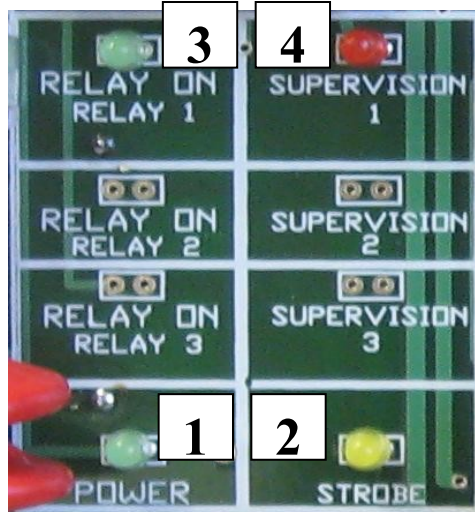

## SUPERVISION FEATURE

The Supervision Feature is a great way for checking at a glance the integrity of the system. This feature will come on after three hours of the receiver not hearing it's correct code from the transmitter. The Supervision light will begin to blink until the receiver hears it's correct code again. If there are two or more receivers on the same transmitter and the Supervision light is blinking on both of them it is indicating that the transmitter is either turned off or malfunctioning. If only one out of the two receiver's Supervision light is blinking it is indicating that that receiver is malfunctioning and that the other receiver and transmitter are good. There is also a supervision light for each of the Relays on the receiver. These are there for when a receiver is going to use it's other relays that are controlled by different transmitters. This will tell you exactly which transmitter is turned off or is not working properly.

## SUPERVISION FAIL SAFE

This feature works with the Supervision feature as described above but lets us take safety a step further. When the receiver has not heard from the transmitter with it's correct code in the last three hours it will go into Fail Safe mode and shutdown it's pump. This is intended to let the servicer know that there is something wrong with the transmitter or the receiver. This Fail Safe shutdown is designed to prevent any spills or damage to machinery or property.

## RECEIVER UNIT 810-3R

**CAUTION:** Never switch any voltage greater than 120v with the Hot Shot Receivers internal relays. This will ruin the relay and void all manufacturer warranties. Use an externally mounted 120v coil relay to switch all voltages greater than 120v. This will be shown later in Electric Well Hookup section.

### ELECTRIC WELL HOOKUP

- Mount a 480v-120v step-down transformer to supply 120v to the receiver. The Hot Shot Receiver only requires 1 watt of power to operate. *Hot Shot Systems suggest using a minimum of a single phase 60 hertz 0.050kVA transformer. They are available for purchase through Hot Shot Systems, just request when ordering.*
- Mount a 3 terminal fuse block and a 120vac relay. *Hot Shot Systems suggest using a 115V AC coil relay. They are available for purchase through Hot Shot Systems, just request when ordering.*
- Wire two, 480v conductors through the first two fuses (1/2 or 1 amp each) to the primary side of the step-down transformer. **Terminals may be different according to the transformer installed.**
- Wire the 120v **X1** terminal of the step-down transformer through the remaining fuse (1 amp) which then goes to the first 120vac input of the Hot Shot Receiver (120 volt polarity does not matter).
- Wire the 120v **X2** terminal of the step-down transformer to the second 120vac input of the Hot Shot Receiver input (see diagram on the next page).
- Add a jumper wire from the receiver's second 120vac terminal to the receiver's relay **COM.** terminal (see diagram on the next page).
- Wire the **N.C.** terminal on the Hot Shot Receiver to one side of the 120v relay coil.
- Connect the other side of the relay coil to the **X1** terminal of the step-down transformer.
- Connect a wire from the **Lighting Ground** terminal of the Hot Shot Receiver to the ground lug of the pump panel.

# RECEIVER UNIT 810-3R

## Electric Well Hookup Diagram

**OBJECT:** WHEN THE HOT SHOT TRANSMITTER 'S RELAY INPUT TO COMMON IS CLOSED IT SENDS OUT THE RELAY ON COMMAND TO THE RECEIVER. WHEN THE HOT SHOT RECEIVER RECEIVES THE ON SIGNAL IT WILL CLOSE IT'S NO TO COMMON CONTACTS. THIS WILL ENERGIZE THE 120V RELAY TO CLOSE THE 480V CONTACTOR.

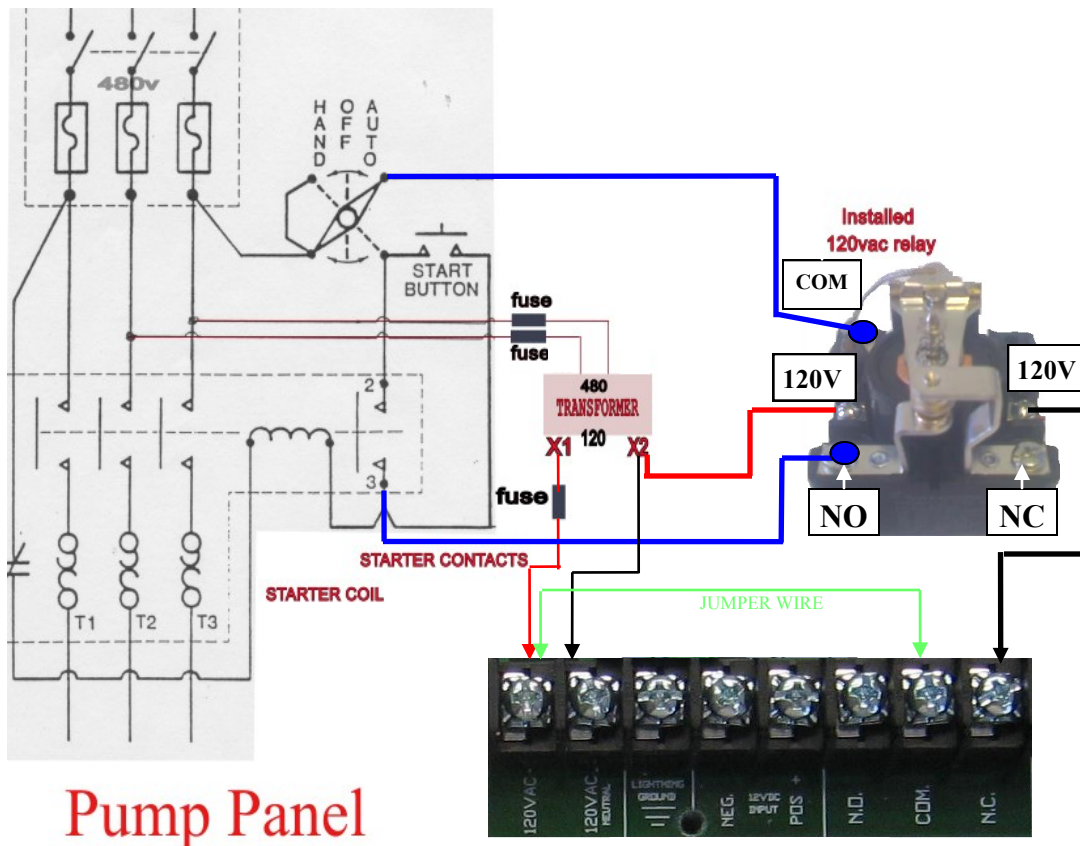

# RECEIVER UNIT 810-3R

## HOT SHOT RECEIVER RELAY INTERFACE TO SHUTDOWN THE ELECTRICAL SYSTEM OF A DIESEL OR GAS ENGINE DRIVEN WELL

### AT THE ENGINE

**DO NOT** mount the HOT SHOT Receiver unit to the well engine or engine cover because strong vibrations can be harmful to the unit.

The diagrams below show a simple way to shutdown an engine using a simple 117 or 518 Murphy kill switch. Supply power to the receiver by hooking up the 12v positive input on the receiver to the 12v positive terminal on the battery. Run a wire from the Negative input on the receiver to the negative terminal on the battery or to a good ground connection. Install a jumper wire connecting the negative input on the receiver to the COM terminal on the receiver. Connect a wire from the N.C. terminal on the Hot Shot receiver to the S or the SW1 terminal on the Murphy kill switch. When the receiver is sent a shutdown signal, the receiver's relay will close COM to NC and short the coil to ground and kill the engine. Other variations and Murphy Kill switches will work as well. **ATTENTION** if you are trying to stop an engine run with a magneto **DO NOT** wire it straight to the receivers relay. Use the receivers relay to control an isolated relay that can handle the extreme voltages.

### Engine Driven Well Hookup Diagrams

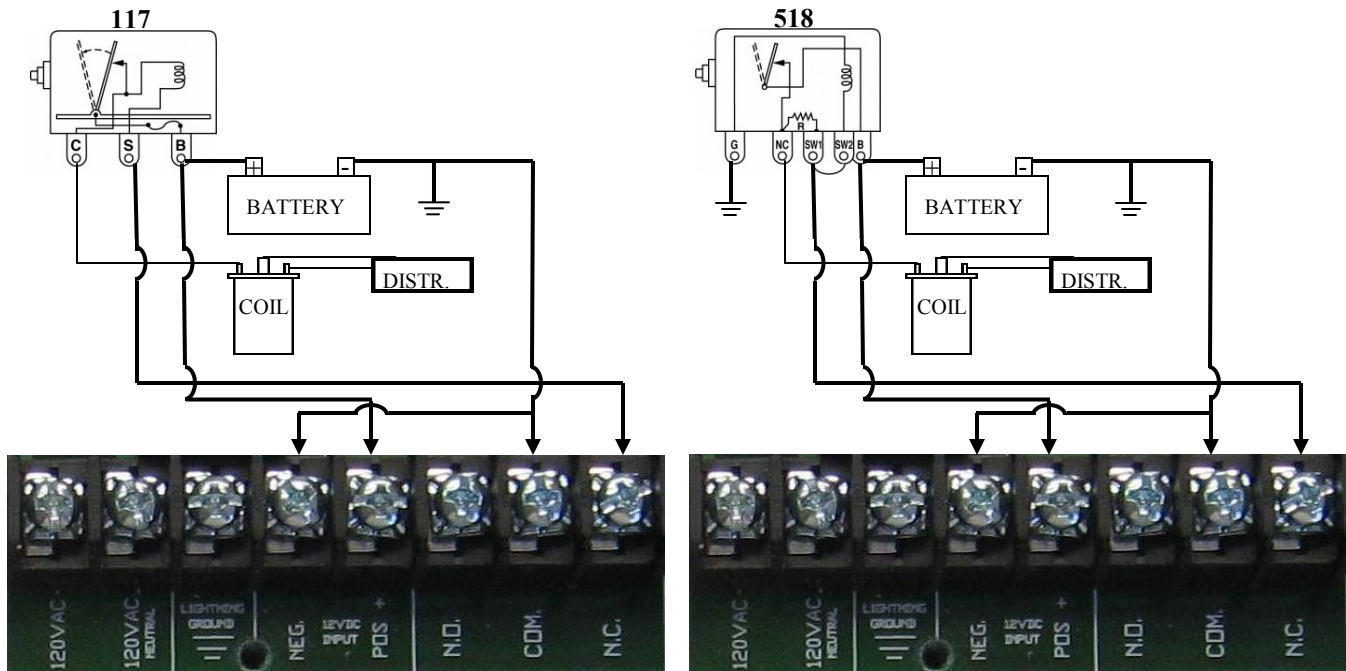

# RECEIVER UNIT 810-3R

## HOT SHOT SOLAR RECEIVER RELAY INTERFACE TO SHUTDOWN A SIMPLE HEAD GAS OR PROPANE ENGINE DRIVEN WELL

### AT THE ENGINE

**DO NOT** mount the HOT SHOT Receiver unit to the well engine or engine cover because strong vibrations can be harmful to the unit.

The diagrams below show a simple way to shutdown an engine using a solar receiver and an external 12v relay to control the engines magneto. **ATTENTION** when stopping an engine run with a magneto **DO NOT** wire it straight to the receivers built-in relay. Use the receivers built-in relay to control an isolated relay that can handle the extreme voltages.

**The momentary function (function switch #1) needs to be turned on in the receiver for this style of operation. See pg 6.** The external 12v relay will be powered by the hot shot receivers 12v terminals. Run a wire from the 12v negative input on the receiver to the negative coil terminal on the 12v external relay. Install a jumper wire connecting the 12v positive input on the receiver to the COM terminal on the receiver. Connect a wire from the N.O. terminal on the receiver to the 12v positive coil terminal on the external 12v relay. Now use one of the terminals on the external relay to connect to a good solid ground and connect the other terminal on the external relay to the magneto on the engine. Now when the receiver is sent a shutdown signal, the receiver's relay will close COM to N.O. and activate the external 12v relays coil connecting the engines magneto to ground and stopping the engine. Other variations and Kill switches may work as well.

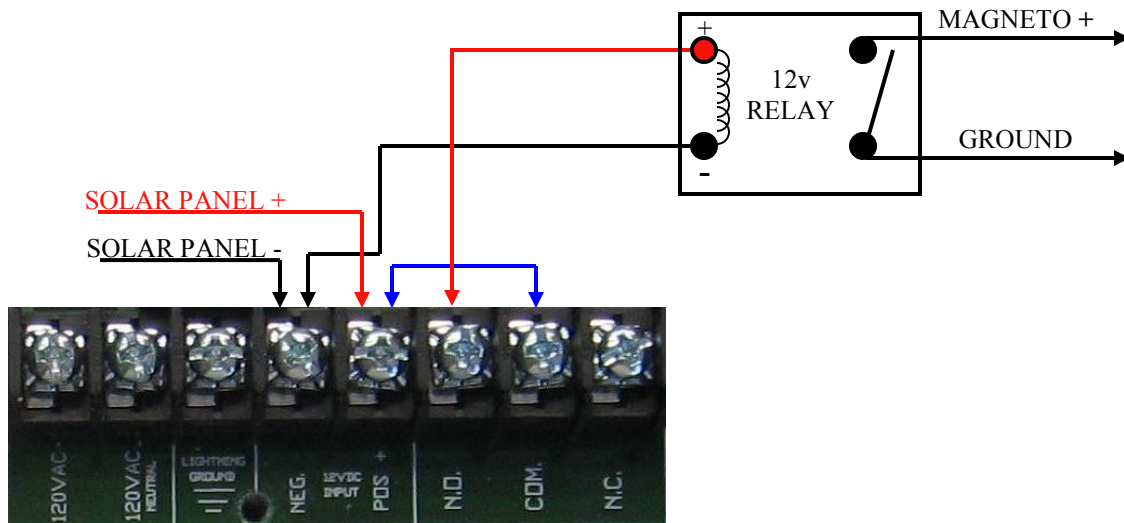

## **RECEIVER UNIT 810-3R**

**NOTE:** This equipment has been tested and found to comply with the limits for a Class B digital device, pursuant to part 15 of the FCC Rules. These limits are designed to provide reasonable protection against harmful interference in a residential installation. This equipment generates, uses and can radiate radio frequency energy and, if not installed and used in accordance with the instructions, may cause harmful interference to radio communications. However, there is no guarantee that interference will not occur in a particular installation. If this equipment does cause harmful interference to radio or television reception, which can be determined by turning the equipment off and on, the user is encouraged to try to correct the interference by one or more of the following measures:

- Reorient or relocate the receiving antenna.
- Increase the separation between the equipment and receiver.
- Connect the equipment into an outlet on a circuit different from that to which the receiver is connected.
- Consult the dealer or an experienced radio/TV technician for help.

### **15.21 INFORMATION to USER:**

The users manual or instruction manual for an intentional or unintentional radiator shall caution the user that changes or modifications not expressly approved by the party responsible for compliance could void the user's authority to operate the equipment.